

**iQ500, free-standing
fridge-freezer with freezer at
bottom, 203 x 60 cm, Brushed
steel anti-fingerprint, Total
noFrost
KG39NAIAU**



Bottom freezer with hyperFresh <0°C> to keep fruit and vegetables fresh for longer, plus noFrost for no more defrosting – enjoy outstanding cooling results in the best energy efficiency and noise level class A.

- ✓ Individual Temperature Control – Individual control and temperature setting of fridge and freezer can save energy.
- ✓ Total noFrost: Never defrost your freezer again and bid farewell to water drops on the fridge backwall.
- ✓ freezerLight: Clever freezer illumination.
- ✓ Metal backwall with multiAirflow: Evenly cooled food and drinks on all levels.
- ✓ hyperFresh <0°C>: More space for fruit and vegetables. A cold climate for fish and meat.

Features

Technical Data

Energy Efficiency Class (Regulation (EU) 2017/1369):A
Average annual energy consumption in kilowatt hour per year (kWh/a) (EU) 2017/1369: 112 kWh/annum
Sum of volume of frozen compartments (EU 2017/1369): 103 l
Sum of volume of chill- and unfrozen compartments (EU 2017/1369): 260 l
Airborne acoustical noise emissions (EU 2017/1369):	...29 dB(A) re 1pW
Airborne acoustical noise emission class (EU 2017/1369): A
Built-in / Free-standing: Free-standing
Number of compressors: 1
Number of independent cooling systems: 2
Width of the appliance: 600 mm
Height: 2030 mm
Depth of the product: 665 mm
Net weight: 97.2 kg
Door panel options:Not possible
Door hinge:Right reversible
Number of Adjustable Shelves in fridge compartment: 3
Shelves for Bottles: Yes
Frost free system:Fridge
Interior ventilator: No
Reversible Door Hinge: Yes
Length electrical supply cord: 210 cm
Noise level:29 dB(A) re 1pW
Multi-Flow Air Tower: Yes
Fast cooling switch: Yes
: Yes
Temperature Controlled Drawer:No
Humidity Control Drawer:No
Number of Door Bins - Refrigerator:3
Door bin adjustability - Refrigerator:Yes
Tilt-out door bins in fridge: No
Gallon Storage:Yes
Number of Gallon storage: 1
Motorized Shelf:No
Material of the shelves: Safety glass
Door opened indicator freezer: No
Automatic motor-driven ice-maker: No
Fuse protection: 10 A
Voltage:220-240 V
Frequency:50 Hz
Storage Period in Event of Power Failure (h): 21 h
Door panel options:Not possible
Noise level:29 dB(A) re 1pW
Energy Star Qualified:Nd /

Required cutout/niche size for installation (in): x
Dimensions of the packed product: 82.48 x 25.98 x 30.70
Net weight: 214.000 lbs
Gross weight: 228.000 lbs



iQ500, free-standing fridge-freezer with freezer at bottom, 203 x 60 cm, Brushed steel anti-fingerprint, Total noFrost KG39NAIAU

Features

- inox easyClean Doors
- Bottom Freezer

Performance and consumption

- Energy Class EU19_EEK_D: A
- Total Volume : 363 l
- Annual Energy Consumption: EU19_Annual energy cons rd_D: 112 kWh/a
- Fast freeze facility: yes
- Noise level: EU19_Noise emission_D: 29 dB

Design

- Doors inox easyClean, side panels Pearl grey (VZF 07127)
- Bar handle
- SoftStart LED light in fridge section
- Metal backwall

Comfort and Safety

- noFrost - no need to for manual defrosting - never again defrosting!
- Display: Twin LED electronic control
- Two Cooling Systems
- Optical and acoustic door open warning system
- Super cool function
- Automatic defrost in fridge section

Fridge Section

- EU19_Unfrozen volume_D: 260 l
- 5 safety glass shelves, of which 3 are height adjustable
- 1 door shelf large, 2 door shelf small

Freshness System

Freezer Section

- Net Freezer Volume:
- EU19_Frozen volume_D: 103 l
- Freezing capacity 24h:
- EU19_Freezing capa. in 24h_D: 10 kg
- Temperature rise time : 21 H
- 3 transparent freezer drawers
- freezerLight

Dimensions

- Dimensions (H x W x D): 203.0 cm x 60.0 cm x 66.5 cm

Technical Information

- Door right hinged, reversible hinging
- Height adjustable front feet, rolls in the back
- Nominal voltage: 220 - 240 V
- Climate class: EU19_Climate class_D: SN-T

- Length of power cord:210 cm

Accessories

- 1 x ice cube tray

Country Specific Options

- Based on the results of the standard 24-hour test. Actual consumption depends on usage/position of the appliance.

General Information

Environment and Safety

Installation

iQ500, free-standing
 fridge-freezer with freezer at
 bottom, 203 x 60 cm, Brushed
 steel anti-fingerprint, Total
 noFrost
 KG39NAIAU

Dimensioned drawings

Measurements in mm

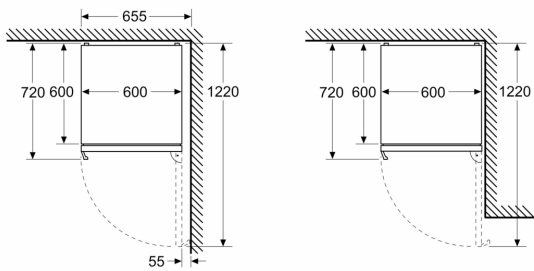

Measurements in mm

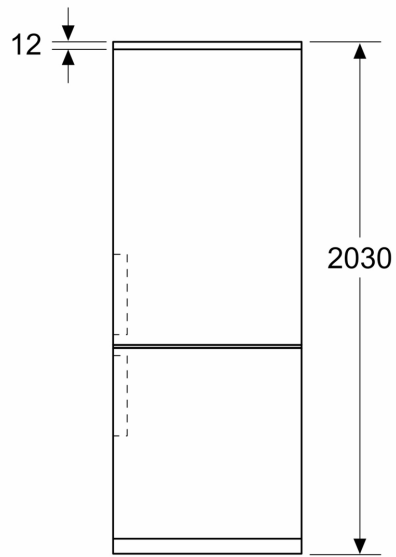

Measurements in mm

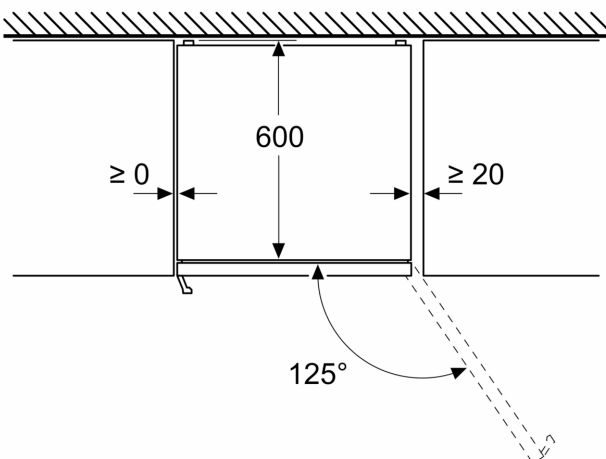

Measurements in mm

